

## TWA 800 A RV (Laadks)





Stark abgesenkte Flachwageneinheit mit Radvorlegern / Flat wagon unit with extreme low floor and wedges /  
Wagon plat à plancher fortement surbaissé avec cales / Carri pianali accoppiati ultra-ribassati con bloccaruote /  
Mycket låg flakvagnsenhet med hjulförstängare / Platforma z klinami - bardzo obniżona /  
Platform Vagonlar daha Alçak tabanlı ve Emniyet Takozlu Sistem ile



UIC	TWA	Dispo-Gruppe
Laadks	TWA 800 A (RV)	800

## TWA 800 A RV (Laadks)

Stark abgesenkte Flachwageneinheit mit Radvorlegern / Flat wagon unit with extreme low floor and wedges /  
Wagon plat à plancher fortement surbaissé avec cales / Carri pianali accoppiati ultra-ribassati con bloccaruote /  
Mycket låg flakvagnsenhet med hjulförstängare / Platforma z klinami - bardzo obniżona /  
Platform Vagonlar daha Alçak tabanlı ve Emniyet Takozlu Sistem ile

 Wagentdaten	 Wagon data	 Caractéristiques techniques	 Caratteristiche tecniche	 Vagndata	 Dane wagonu	 Vagon detayları	Laadks
Stark abgesenkte Flachwageneinheit mit Radvorlegern	Flat wagon unit with extreme low floor and wedges	Wagon plat à plancher fortement surbaissé avec cales	Carri pianali accoppiati ultra-ribassati con bloccaruote	Mycket låg flakvagnsenhet med hjulförstängare	Platforma z klinami - bardzo obniżona	Platform Vagonlar daha Alçak tabanlı ve Emniyet Takozlu Sistem ile	
Dispo-Gruppe	Order group	Code groupe	Gruppo Dispo	Dispogrupp	Typ wagonu	Vagon Grubu	
Wagenlänge über Puffer	Overall length over buffers	Longueur hors tout	Lunghezza carro tra i respingenti	Längd över buffertar	Długość wagonu ze zderzakami	Tamponlar arası uzunluğu	27.000 mm
Ladelänge	Loading length	Longueur utile	Lunghezza del piano di carico	Lastytans längd	Długość przestrzeni ładunkowej	Yükleme Boyu	25.760 mm
Horizontale Ladelänge	Horizontal loading length	Longueur utile à l'horizontal	Lunghezza del piano di carico in piano	Lastytans horisontella längd	Pozycja długość ładunkowa	Düz Yükleme uzunluğu	18.870 mm
Ladebreite	Loading width	Largueur utile	Larghezza del piano di carico	Lastytans bredd	Szerokość przestrzeni ładunkowej	Yükleme Eni	3.110 mm
Fußbodenhöhe über Schienenoberkante	Height of wagon floor over rail	Hauteur du plancher au-dessus du rail	Altezza del piano di carico dal piano rotaia	Lastytans höjd över rälsöverkant	Wysokość podłogi nad główką szyny	Platformun Raydan Yüksekliği	800 mm
Zulässige Fußbodenbelastung (nach UIC-531)	Maximum floor pressure allowed according (to UIC-531)	Limite de charge du plancher (selon UIC-531)	Limite di portata del pavimento (a norma UIC-531)	Högsta tillåtna golvbeklastning (enligt UIC-531)	Dopuszczalne obciążenie podłogi (wg UIC-531)	Maksimum Taban taşıma kapasitesi (UIC-531)	50 kN
Eigengewicht	Tare weight	Tare	Tara	Egenvikt	Masa własna	Darısı	ca. 24.500 kg
Lastgrenze C	Payload C	Limite de charge sur ligne C	Limite di portata (Linee classe C)	Lastgräns C	Dopuszczalna masa brutto (klasa C)	Yükleme Sınırları (C Hatları)	ca. 47,5 t *
Lastgrenze B	Payload B	Limite de charge sur ligne B	Limite di portata (Linee classe B)	Lastgräns B	Dopuszczalna masa brutto (klasa B)	Yükleme Sınırları (B Hatları)	ca. 47,5 t *
Lastgrenze A	Payload A	Limite de charge sur ligne A	Limite di portata (Linee classe A)	Lastgräns A	Dopuszczalna masa brutto (klasa A)	Yükleme Sınırları (A Hatları)	ca. 39,5 t
Kleinster befahrbarer Gleisbogenhalbmesser	Minimum curve radius	Rayon minimum de passage en courbe	Raggio minimo di curvatura	Minsta kurvradie	Minimalny promień skrętu	En az Kurp Yarıçapı	75 m
Zusatzdaten pro Wagenhälfte	Extra information by half wagon	Données complémentaires par demi-wagon	Dati supplementari per semicarro	Tilläggsdata per vagnhalva	Dodatkowe informacje do jednostki wagonu krótkosprzężonego	Vagon Yarısı için diğer bilgiler	
Radvorleger (versenkbar)	Wedges (depressable)	Cales (amovibles)	Bloccaruote (a scomparsa)	Hjulförstängare (nedsänkbar)	Kliny (wpuszczane w podłogę)	Emniyet takozlar (Adet)	16 units
Verzürösen (versenkt in Wagenmitte)	Securing rings (depressed in middle of wagon)	Anneaux d'arrimage (abaissés au milieu du wagon)	Occhielli di ancoraggio (a scomparsa al centro del carro)	Lastsäkringsöglor (nedsänkta i vagnsmitt)	Uchwyt do lin zabezpieczających ładunek (boczne lub podłogowe)	Sabit kancalar (kenarda ve vagonun ortasında)	8 units
Bindeösen (seitlich)	Anchorage points (on the side)	Points d'ancrage (latéraux)	Occhielli laterali di ancoraggio	Surringsöglor (på sidorna)	Oczka do przewiązania lin zabezpieczających ładunek (boczne)	Gergi halatı (kenarda)	14 units
Tragfähigkeit	Payload	Capacité de charge	Portata	Lastförmåga	Dopuszczalny ciężar ładunku	Yükleme Kapasitesi	ca. 23,75 t
* Verminderung auf Streckenklasse A auf einigen Strecken.	* Reduction on line category A on some tracks.	* Limitation à la charge de ligne A sur certains parcours	*Riduzione a classe A su alcuni percorsi	Minskning till linjeklass A på enstaka sträckor	*Ograniczenie na trasie kategorii A na niektórych odcinkach	* A hat sınıf güzergahlarında yükleme limitlerinde azaltma olaabilir	
Lochschiene	Rail to fix wedges	Rails de fixation des cales	Guida forata	Låsskena	Szyna prowadząca	Delikli Ray	
Führungsschiene	Check rail for wedges	Rails de guidage des cales	Guida	Styrskena	Szyna prowadząca	Bilyeli Ray	

## TWA 800 A RV (Laadks)

Stark abgesenkte Flachwageneinheit mit Radvorlegern / Flat wagon unit with extreme low floor and wedges /  
 Wagon plat à plancher fortement surbaissé avec cales / Carri pianali accoppiati ultra-ribassati con bloccaruote /  
 Mycket låg flakvagnsenhet med hjulförstängare / Platforma z klinami - bardzo obniżona /  
 Platform Vagonlar daha Alçak tabanlı ve Emniyet Takozlu Sistem ile

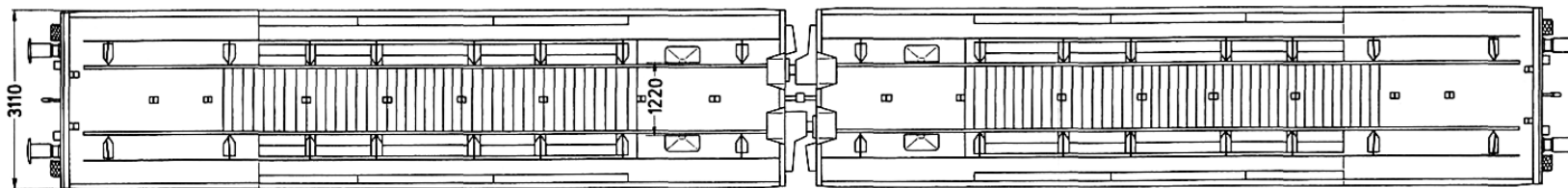
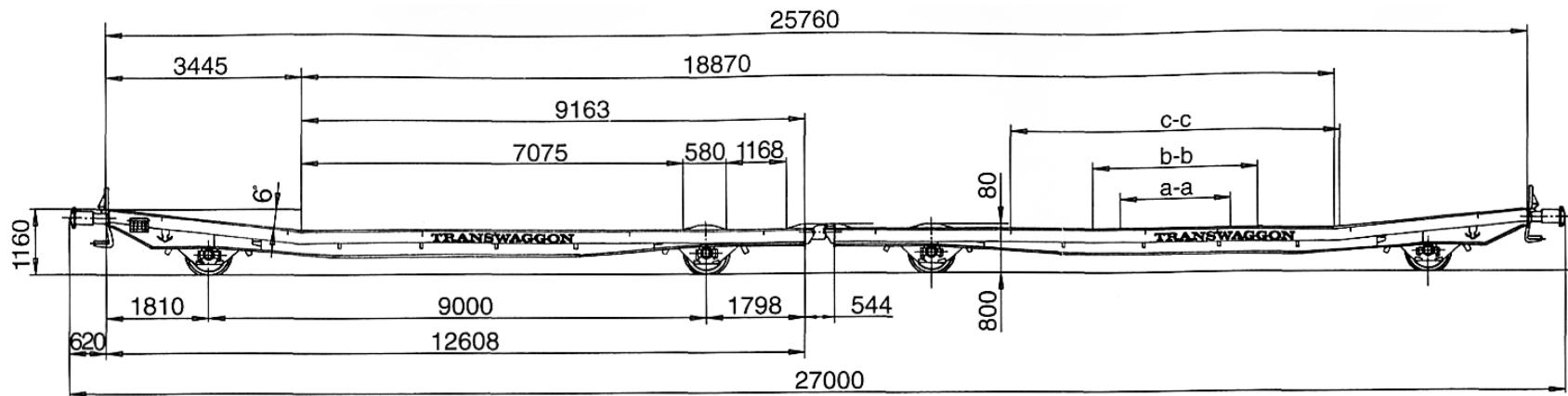

	A	B	C
S	39,5 t	47,5 t*	
120	00,0 t		

\* Verminderung auf Streckenklasse A auf einigen Strecken

	m	t	▲▲
a-a	2	15,0	17,0
b-b	3	16,0	20,0
c-c	7	22,0	23,5

